

SPI-A3 FINISH ALL OUTSIDE SURFACES.
INSIDE AREAS POLISHED SPI D-2 OR BETTER.

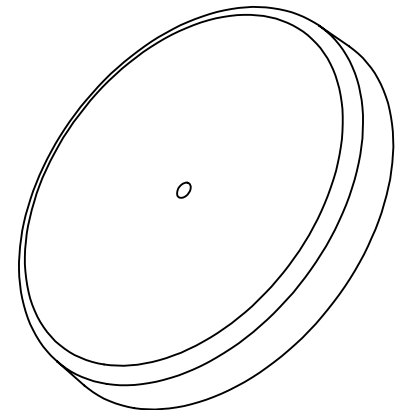
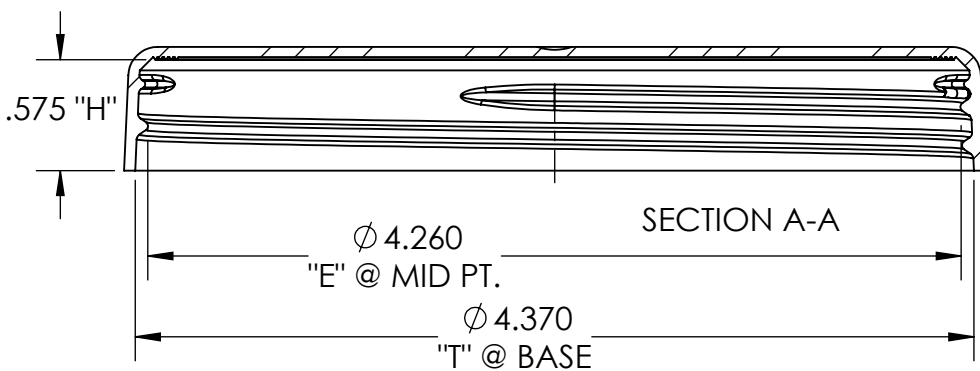

ADVERTISING DRAWING
NOT FOR QUALITY CONTROL

THREAD DATA:
SPECIAL 110-400 FINISH
.200 PITCH (5 TPI)
APPROX. 1-1/4 TURNS

<p>PROPRIETARY AND CONFIDENTIAL THE INFORMATION CONTAINED IN THIS DRAWING IS THE SOLE PROPERTY OF COMET TOOL COMPANY. ANY REPRODUCTION IN PART OR AS A WHOLE WITHOUT THE WRITTEN PERMISSION OF COMET TOOL COMPANY IS PROHIBITED.</p>			<p>DIMENSIONS ARE IN INCHES TOLERANCES: FRACTIONAL $\pm 1/64$ ANGULAR: $\pm 1^\circ$ TWO PLACE DECIMAL $\pm .030$ THREE PLACE DECIMAL $\pm .015$</p>	NAME	DATE	<p>COMET TOOL COMPANY</p> <p>SMOOTH WALL 110-400 CAP</p>	
				DRAWN	MP		4-12-19
				CHECKED			
				ENG APPR.			
				MFG APPR.			
				Q.A.			
				COMMENTS:			
	NEXT ASSY	USED ON	FINISH	SEE NOTE			
	APPLICATION		DO NOT SCALE DRAWING				
	SIZE	PART NO.	WEIGHT:			REV.	
	A	1340-0027					
	SCALE: 1:1					SHEET 1 OF 1	